



# Original Schematic MODEL 5F6-A

I-66

## NOTICE

VOLTAGES READ TO GROUND  
WITH ELECTRONIC VOLTMETER  
VALUES SHOWN  $\pm$  OR  $- 20\%$

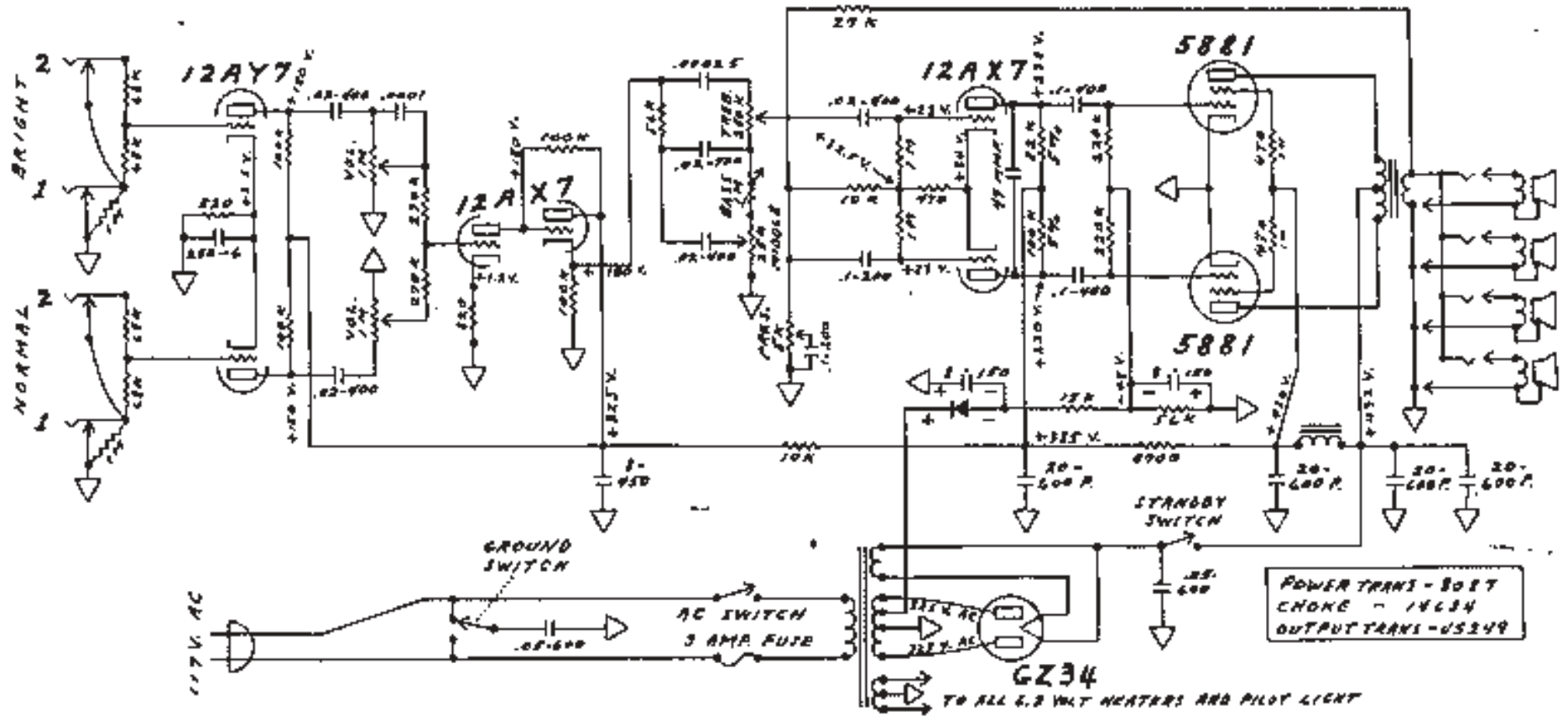

HATCHER  
**Amps**  
vintage

Super 45 Schematic

24700 CENTER RIDGE RD CLEVELAND, OH 44145  
Phone: (440) 871-9090 • www.hatcheramps.com





## Super 45 Board Kit parts listing

### ON BOARD 1/2 WATT RESISTORS

- 2 100 OHM
- 1 470 OHM
- 2 820 OHM
- 1 1K
- 1 10K
- 1 15K
- 1 27K
- 1 47K
- 1 56K
- 1 82K
- 5 100K
- 2 220K
- 2 270K
- 2 1M

### OFF BOARD 1/2 WATT RESISTORS

- 2 1.5K
- 4 68K
- 2 1M

### ON BOARD 2 WATT RESISTORS

- 2 1 OHM

### ON BOARD 3 WATT RESISTORS

- 2 470 OHM
- 1 4.7K
- 1 10K

### ON BOARD CAPACITORS

- 1 250P
- 5 .022/630V
- 1 .1/250V
- 2 .1/630V
- 2 10/100V
- 1 220/35V

### OFF BOARD CAPACITORS

- 1 100P
- 1 .1/250V

### ON BOARD MISC

- 1 50K BIAS POT
- 1 1N4007 DIODE
- 6 1/4 STANDOFFS
- 6 5/8" SCREWS
- 6 NUTS
- 1 1/8" THICK CIRCUIT BOARD 10 1/2"
- 77 TURRET LUGS

### OFF BOARD MISC

- 3 1MA POTS
- 1 250KL POT
- 1 25KL POT
- 1 5KL POT
- 4 12A JACKS
- 5' Solid 20ga RED, GREEN, BLACK, WHITE
- 5' Stranded 18ga RED, GREEN, BLACK, WHITE
- 2' MINI SHIELDED CABLE
- 4 ROUND RING TERMINALS
- 1 2" x 3/16" HEAT SHRINK TUBING
- 1 LAYOUT DIAGRAM
- 1 SET OF INSTRUCTIONS

## Super 45 Bassman Kit

- 1 5F6A repro chassis - the tube sockets below fit this chassis
- 3 9 pin fender style tube sockets
- 3 8 pin ceramic tube sockets
- 4 RCA chassis jacks
- 1 Power cord (8 or 12 foot)
- 1 Power cord strain relief
- 1 Power cord clamp
- 1 Fender lamp assembly
- 1 Bulb
- 1 Jewel (your choice of color)
- 1 Spst carling power switch
- 1 Spst carling standby switch
- 1 Spdt carling ground switch (Not necessary with 3 prong power cord)
- 1 Fender style fuse holder
- 1 3 amp slo-blo fuse
- 1 022798 Power transformer
- 1 022855 (2 ohm) or 018343 (multi tap) output transformer
- 1 125C1A fender choke
- 6 Black chicken head knobs
- 1 Filter cap can or see my filter cap documents on the info page.
- 5 20/500v or 22/500v filter caps
- 1 5U4G or 5AR4 rectifier tube
- 2 6L6EH power tubes
- 2 12AX7WA pre amp tube
- 1 12AY7 pre amp tube (Mod: A 12AX7 can be used instead for more gain.)
- 1 5F6A Board kit - The Hoffman board kit has all the parts mounted
- 1 Filter Cap Kit



Parts Listing

24700 CENTER RIDGE RD CLEVELAND, OH 44145  
Phone: (440) 871-9090 • www.hatcheramps.com

# BOARD KIT INSTRUCTIONS

This kit should contain, depending on the kit.

- 1- Set of instructions (You are reading them now).
- 1 - Layout diagram.
- 4 - #12A 1/4 input jacks.
- 4 - 68k input jack resistors.
- 2 - 1meg input jack resistors.
- 1 - Circuit board with all mounting hardware (standoffs, screws, nuts)
- 1 - Pot harness assembly.
- 2 - 1.5k Fender or 2 - 5.6k Marshall or 4 - 1.5k Vox grid resistors.
- 2- 6.8k mid control resistors on AB763 kit
- 1 – 220k reverb jack resistor on AB763 and Reverb unit kits.
- 4 - Round terminal lugs for chassis ground connections.
- Assorted green, red, black and white wire.
- Shielded cable for input jacks.
- Heat shrink tubing for shielded cable

**WARNING: DO NOT WORK ON ANY AMPLIFIER WITH THE AC PLUG PLUGGED INTO THE WALL SOCKET! ALWAYS DISCHARGE THE FILTER CAPS BEFORE WORKING ON AN AMPLIFIER!**

**IF YOU ARE UNSURE OF HOW TO DO SOMETHING PLEASE TAKE IT TO A TECHNICIAN!**

## NOTES:

- \* When you see this on the layout diagram 820/220. It means there is an 820 ohm resistor with a 220uf cap in parallel across the resistor.
- \* V12= Valve 1, pin 2
- \* The numbers on the pots go to the same number on the board. Example: There is number 1 on volume pot. Find the number 1 on the board and connect the two points with a wire.

## INSTALLATION INSTRUCTIONS FOR ADD ON BOARDS.

1. Place the circuit board inside the amplifier where it will be installed and use a sharp object or a pencil to mark the location of the mounting holes. Make sure to look under the chassis to make sure that you are not going to be drilling into an object such as a transformer on the other side of the chassis. If the mounting holes happen to be where a transformer is, then you can either move the transformer or shim up the transformer using washers so that transformer is not setting on the screw heads of the circuit board mounting screws. You can also make a new mounting hole in the circuit board and move the mounting point.
2. Remove the board and use a punch to mark where the holes will be drilled. Drill the mounting holes using a 11/64 drill bit. The bit should be just slightly larger than the mounting screws, so it will be easier to position the board.
3. Mount the board into the amplifier using the supplied circuit board standoffs between the chassis and the board. If possible keep the heads of the screws on the chassis side and the nuts and washers on the inside of the chassis. If you are also installing transformers, you may want to install them first if any screw heads are going to be under the board.



Instructions

24700 CENTER RIDGE RD CLEVELAND, OH 44145  
Phone: (440) 871-9090 • www.hatcheramps.com

4. Face the front of the amp towards you just like the wiring diagram and start with the first pre-amp tube. On the pre-amp tubes you should do each pin in a counter-clockwise logical sequence. Use the following wire colors when wiring the amp.

(PIN 3, CATHODE 1, V1A -- BLACK WIRE) (PIN 8, CATHODE 2, V1B -- BLACK WIRE)

(PIN 2, GRID 1, V1A ----- WHITE WIRE) (PIN 7, GRID 2, V1B ----- WHITE WIRE)

(PIN 1, PLATE 1, V1A ----- RED WIRE) (PIN 6, PLATE 2, V1B ----- RED WIRE).

HEATER NOTES: Pins 4 and 5 are connected together and are one side of the 6.3 volt ac heaters. Pin 9 is the other side if the heaters. The heater wires should already be wired up on your amp. If you are building from scratch you will have to run your heater wires in a serial twisted pair manner to each tube socket. Use green 18 gauge stranded wire for the power tubes and 20 gauge solid for the pre-amp tubes. Run the twisted pair heater wires about an inch over the top of the tube sockets and come straight down to the pins. Some amp builders like to keep the pins the same, socket to socket. For example, pin 9 on the first pre-amp tube would continue on to pin 9 of the next tube and so on down the line. The power tube heater pins are 2 and 7, and you can do the same thing when you wire them.

5. Attach each wire to a turret lug first and then to the tube socket pin last. Starting with PIN 3 of the first pre-amp tube, strip enough of the black hook up wire so that it can wrap around the base of the turret lug. If you make a half loop around a piece of tubing or something roughly the same size as the lug it is easier to form the wire around the base of the lug. Solder the wire to the turret lug with enough heat to solder the wire correctly, but not so much heat that you unsolder the components from the lugs. Then lay the wire out and run it up to the pin on the tube socket. The wires should not be over the top of the tube socket. They should go around the socket on their way to the pin they will be connected to. The heater wires going to PINS 4, 5 and 9 usually are suspended in the air above the socket and you do not want to be close to those wires. Cut the wire to the correct length. The wires should not be too long or too short. They should be as short as possible with just a little curve for flexibility. Strip the wire and solder it to the correct tube socket pin. Check the lay

out diagram often to see if you are connecting everything correctly. You may want to keep the red wires, going to PINS 1 and 6, away from the black and white wires. You can suspend the red wires above the other wires or the other way around but they should not be laid next to or parallel to the black and white wires. The red plate wires contain the high voltage and may induce noise into the other wires. Solder all the pre-amp tubes first and then go on to the power tubes. (TIP: If the solder on the top of the turret lug gets sucked down into the lug, wait until the lug has cooled down and then return to the lug to add a little bit of solder around the hole in the lug where the components are inserted. Never keep adding solder to a hot lug that keeps sucking it in. First, you are probably heating up the component too much and secondly the lug may be dripping solder out the bottom. This may lead to a solder blob that could touch the metal chassis and short out the board. Solder all the wires to the tube sockets and then come back and resolder the tops of the lugs all at once after everything has cooled down.)

POWER TUBE NOTES: The power tubes cathode, PIN 8 and PIN 1 (BLACK) are connected together and then soldered to the 1 ohm resistors on the board. The current of each power tube can now be checked across each 1 ohm resistor. Also with PIN 1 and 8 tied together you could use EL34 or 6550 power tubes if your power transformer can handle it. PIN 3, the plate, should already be connected to the output transformer. PIN 4 is the screen (red wire) and it is connected to the (1K/5W or 470 ohm/3W) screen grid resistors on the board. PIN 5 is the grid (white wire) and it is connected to a (5.6K or 1.5K) resistor that is soldered to PIN 6. PIN 6 is then connected to the junction of the 220K resistor and the .022 capacitor on the board. PINS 2 and 7 are the heaters.

6. Install the pots into the front panel. Install the jacks into the front panel. Connect the bare ground buss wire from the pots to the ground of the jacks. Connect the black ground wire from the left end of the circuit board to the bare ground buss that runs along the backs of the pots and goes to the jacks. Install the two 68K and one 1M resistors on each set of jacks. The shielded cable should be soldered to the input jacks and then go to the first tube to pins 2 and 7. Cut the cable to the correct length by routing it directly from the two 68K resistors to the tube socket. Leave just a little slack in the shielded cable. Strip the cable and



## Instructions

24700 CENTER RIDGE RD CLEVELAND, OH 44145  
Phone: (440) 871-9090 • [www.hatcheramps.com](http://www.hatcheramps.com)

connect the center wire to the junction of the two 68K resistors. Connect the shield of the cable to the ground buss on one of the jacks. Strip the tube socket end and remove the outer shield. You will only connect the center wire to the tube socket pin. Use some heat shrink to cover the outer shield on the tube socket end so it does not touch anything and cause problems. Shrink the heat shrink with the barrel of your soldering iron.

7. Connect each pot connection using the white wire. Strip one end of the white hook up wire and solder it to the pot tab and then find the location on the board where the wire will be attached. Cut the wire as short as possible leaving just a little play in the wire. Strip the end of the wire and insert it into the hole in the top of the lug. The wire will be in the hole with the component. Solder the top of the lug carefully using just enough heat. A sharp soldering iron tip is a big help when doing fine soldering like this.

8. Hook up the feedback wire. Soldered a white wire to one end of the FEEDBACK RESISTOR and solder the other end to the speaker tap you are going to use. (8 ohm in MARSHALL'S)

9. Find the black ground wire at the right end of the board and connect this wire to the chassis ground. If the amp has a center tap, connect the ground wire to the chassis where the center tap of the power transformer is connected.

10. Connect each filter cap positive end to the correct location along the power supply rail. This rail is along the front edge of the board closest to the pots. Look at the layout diagram to see where each filter cap should be connected. Wrap the wire around each turret lug and solder it. The filter cap grounds should technically be connected as close as possible to the cathode of the tube that they go to, but this is usually not possible. In FENDER style amps the filter caps are in a can on the back of the amp and you can use the stock method of filter cap grounding. In MARSHALL style amps each cap is grounded to the chassis and flows through the chassis back to the center tap.

11. If your power transformer doesn't have a heater center tap then solder a green wire from each heater wire on the first power tube (PINS 2 AND 7) and connect the two wires to the two 100 ohm resistors on the right end of the circuit board. If you are running your own heater wires, then solder the heater wires from the power transformer to the two 100 ohm resistor lugs and then connect all the heaters starting from the circuit board. The two 100 ohm resistors make an artificial ground to prevent hum.

12. Connect the bias tap from the transformer to the bias range resistor on the board. This resistor may have to be changed up or down in value to get a correct bias range.

13. Connect the high voltage wires from the power transformer to the two diodes on the board if your board has an on the board rectifier. If you have a tube rectifier, pin 8 of the rectifier tube should go to the standby switch first and then from the standby switch to the B+ point on the power rail. The MARSHALL board is set up to use a half wave rectifier like the original amps. Some MARSHALL'S and other amps use a bridge rectifier instead. If your power transformer uses a bridge rectifier we can supply you with a separate bridge that you can bolt down on the chassis, or on the board.

14. Connect the choke from the B+ to the next lug on the power rail to bridge the gap between B+ and the screens.

15. After all connections have been made and double checked, (please take the time to double check all connections). Power up the amp with no tubes in the sockets. Using a multi-meter set on DC volts, check to see if pins 1 and 6 on the pre-amp tubes have high voltage. Check pins 3 and 4 on the power tubes to see if they have high voltage. Check pins 5 on the power tubes to see if they have negative voltage. Turn the bias pot so that pin 5 has the most negative voltage that the bias circuit can produce. This is done so that the power tubes will be over biased when you first turn on the amp with the tubes inserted. You should have at least negative 50 or -50 volts available in the bias circuit. If not, the bias range resistor in the bias circuit cuts down the AC voltage coming from the power transformer and you will have to raise or lower the value to get a correct bias range. Switch your meter to AC volts and make sure you have roughly 6.3 volts of heater voltage across the tube sockets. If all the voltages look correct, turn off the amplifier.

16. Insert all tubes into their sockets. Power up the amp and let it warm up for 30 seconds. Connect your multi meter across one of the 1 ohm power tube cathode resistors. (positive closest to the tubes, negative closest to the front of the amp.)



## Instructions

24700 CENTER RIDGE RD CLEVELAND, OH 44145  
Phone: (440) 871-9090 • [www.hatcheramps.com](http://www.hatcheramps.com)



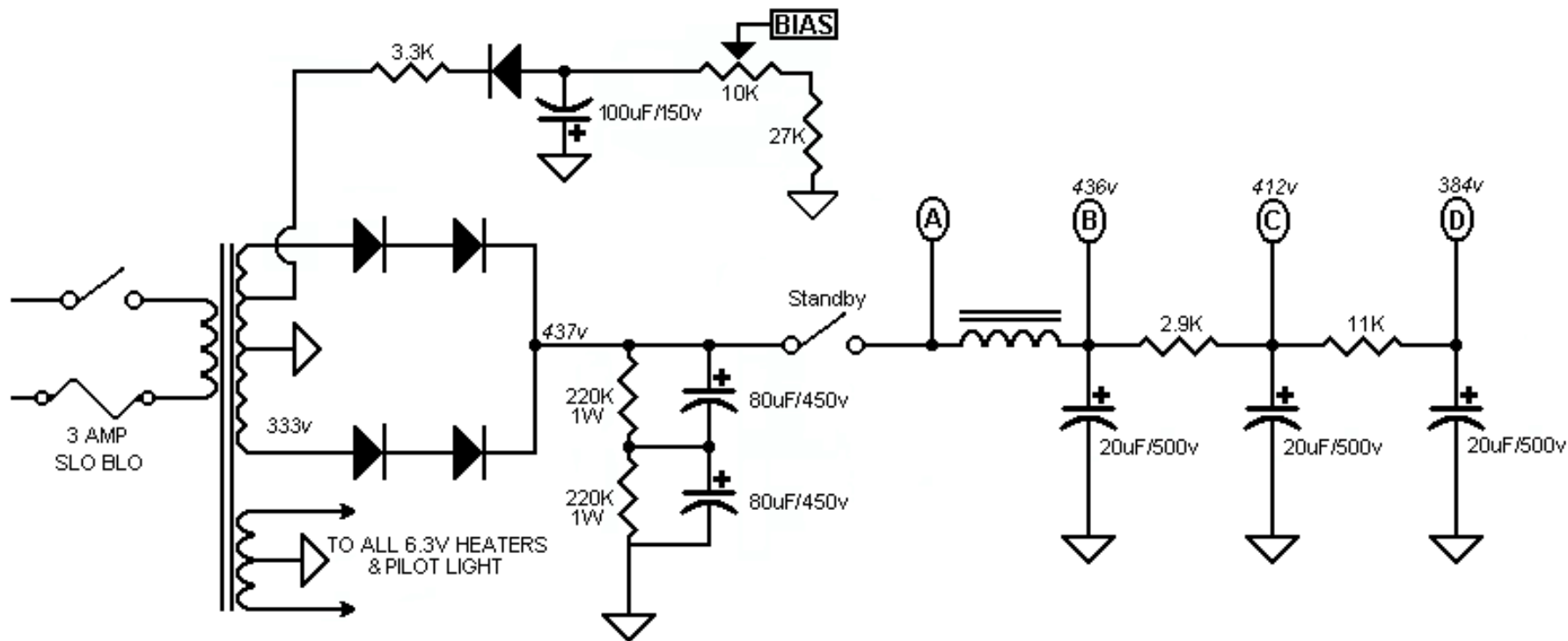

	<p style="text-align: center; font-size: 2em; font-family: cursive;">Solid State P/S</p> <p style="font-size: 0.8em;">24700 CENTER RIDGE RD CLEVELAND, OH 44145 Phone: (440) 871-9090 • www.hatcheramps.com</p>
---------------------------------------------------------------------------------------	---------------------------------------------------------------------------------------------------------------------------------------------------------------------------------------------------------------------